

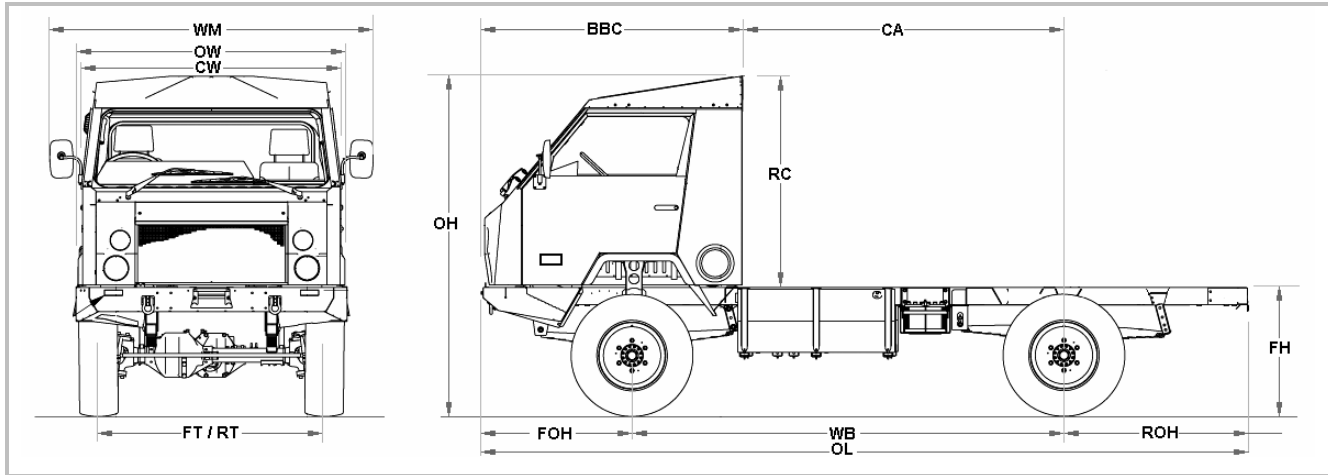

OKA NT 4x4 Single Cab Chassis

EURO 5 (NT24 E5 65-185)

Technical data MY 2011



Dimensions mm (Fully fuelled, unladen. Drawing may depict optional equipment)

OL Overall Length	OH Overall Height	OW Overall Width	CW Cab Width	WM Width Mirrors	FT Front Track	RT Rear Track
5648	2508	2000	1900	2340	1664	1664
WB Wheelbase	FOH Front O'hang	ROH Rear O'hang	BBC Cab Length	CA Cab to R Axle	FH Frame Height	RC Rear of Cab
3190	1101	1357	1917	2374	950	1558

Engine

- Emission class: EURO5
- Type: Cummins ISB4.5E5185
- No. and arrangement of cylinders: 4 in-line
- Technology: SCR
- Diesel direct injection turbocharged & intercooled: 4 stroke
- Power output: kW (hp) 136 (185)
- At rated speed: rev/min 2500
- Maximum torque: Nm 700
- At rated speed: rev/min 1200-1700
- Displacement: cm³ 4500
- Coolant – water: Thermostatic fan
- Fuel tank: litres 120
- AdBlue tank: litres 43

Axles

- Front axle: OKA heavy duty beam type - drive steer with free-wheeling hubs and hub step
- Ratio: 4.62:1
 - Capacity: kg 3200
- Rear axle: OKA heavy duty beam type
- Ratio: 4.62:1
 - Capacity: kg 3800

Brakes

- Service brake: Ventilated disc brakes front and rear. Power boosted air over hydraulic
- Diameter front: mm 350
 - Diameter rear: mm 350
- Park brake: Drum type on transfer case – spring application, air release
- Drum diameter: mm 178

Chassis

Box section straight rail
Flat welded ladder frame construction

Electrics

System: 24 V, 90 Amp alternator.
Lighting: Dual beam headlamps and driving lights, Indicators..

Cab (standard equipment)

Forward control 2 door welded construction, with zinc coated steel sheet panels, built to ROPS safety standard (AS1636-1984). Laminated windscreen, 2 speed + intermittent wipers and washers. Rear view mirrors. 2 seats with seatbelts (single action, detachable for easy servicing), steering lock, demister, interior sunvisors, glove box, cigarette lighter. Driver's cab air-conditioning. Radio AM/FM/CD
Gauges: Speedometer, trip meter, odometer, tachometer, fuel level, water temperature, oil pressure, volt meter, clock
Warning lights: Oil pressure, water temp, charge high beam, indicators, brake failure, 4WD Engagement.

Transmission

- Allison 1000 series automatic with park pawl
6 forward gears, 1 reverse
- Ratio spread: 3.10-0.61:1
 - Torque converter stall: 1.73:1
- With power and economy modes
With overdrive (5th & 6th gear) lock-out
- Transfer box: OKA HD250
- Ratio: High 1.00:1
Low 2.00:1
 - Available combinations: 4 High
4 Low
Neutral
2 High

Steering

Power assisted variable ratio with damper

Suspension

Front: 12 leaf OKA Flex suspension with single rate semi-elliptic multi-leaf springs and Aeon second stage helper springs. High performance long-stroke double acting shock absorbers
Rear: 13 leaf OKA Flex suspension with dual rate semi-elliptic multi-leaf springs and Aeon third stage helper springs. High performance long-stroke double acting shock absorbers.

Wheels and tyres

Wheels: 4 road wheels (single on rear)
Rim size: 19.5" x 8.25" one piece rim
Tyres: 305/70R19.5 Continental HDR
Spare wheel and tyre on winch type carrier

Weights (basic execution)

Gross vehicle mass GVM	kg	6500
Permissible front axle load	kg	3200
Permissible rear axle load	kg	3800
Tare weight*	kg	3600
Gross Payload*	kg	2900
GCM	kg	9000
Max braked trailer weight	kg	4500

*Tare and payload do not take into account weight of tray bodies or options

Performance indicator

• Maximum cruising	Km/h	120
• Maximum gradient	%	55
• Turning circle	m	14.5

Optional accessories

- Dropside steel tray 3685 mm internal length*
- Alternative trays 2395 and 1770mm*
- Tail lamp kit
- Rear light bar
- Front axle differential lock
- Rear axle differential lock
- Air-conditioning ducted to rear of cab for body - various possibilities of ducting / fans
- Bull bar
- Tow bar
- Cruise control (manual or auto)
- Hub step – rear wheels
- External sun visor
- Fire Extinguisher
- Auxiliary fuel tank 170 litres
- Water tank 95 litres
- Auxiliary battery system
- Electric winch – capacity 15000 lb (66.7kN)
- Bluetooth radio AM/FM/CD
- Bluetooth radio AM/FM/CD with PA system
- Speed limiter setting
- Rust proofing
- Light bar with beacons and work light
- First aid kit
- Tachograph
- Spotlights
- Pacbrake PRXB exhaust brake
- Air access point

*Add weights for dropside trays:

3685mm = 425kg

2395mm = 305kg

1770mm = 247kg

Special Vehicle Options

- 335/80R20 Michelin XZL tyres on 9.00" x 20" 3 piece rims
- CTIS (central tyre inflation system) kit on 8.25" x 19.5" rims with beadlock
- CTIS (central tyre inflation system) kit on 9.00" x 20" rims with beadlock
- Air beadlock for 8.25" x 19.5" 1 piece rim
- Air beadlock for 9.00" x 20" 3 piece rim
- Air beadlock for 8.25" x 19.5" bolt-together
- Air beadlock for 9.00" x 20" bolt-together
- Rubber beadlock (for 20" split rims)
- Exit hatch on driver's cab
- NATO black-out lighting
- NATO trailer hitch and trailer plugs

Optional wheel and tyres

- Bolt-together rims 8.25" x 19.5"
- Hankook DH05 305/70R19.5 tyres
- Additional spare wheel and tyre assembly to match tyre equipment fitted

Optional seating

- Vinyl seat trim
- Holdsworth seat trim

	<p>OKA – all terrain solutions Designed and manufactured in Australia by Reymer Pty. Ltd. 45 Miguel Road (PO Box 1307, Bibra Lake, WA 6965) Bibra Lake, WA 6163 Tel; (+61) 08 9434 1300, Fax; (+61) 08 9434 1659, e-mail; sales@oka.com.au, web; www.oka.com.au ABN 91009250784</p>	<p>Dealer</p>
---	---	----------------------

Reymer Pty Ltd has a policy of continuous product improvement and reserves the right to alter any specification without notification.
Copyright Reymer Pty Ltd 2010 - this document may not be shown, lent or copied without express permission of the company. All rights reserved