

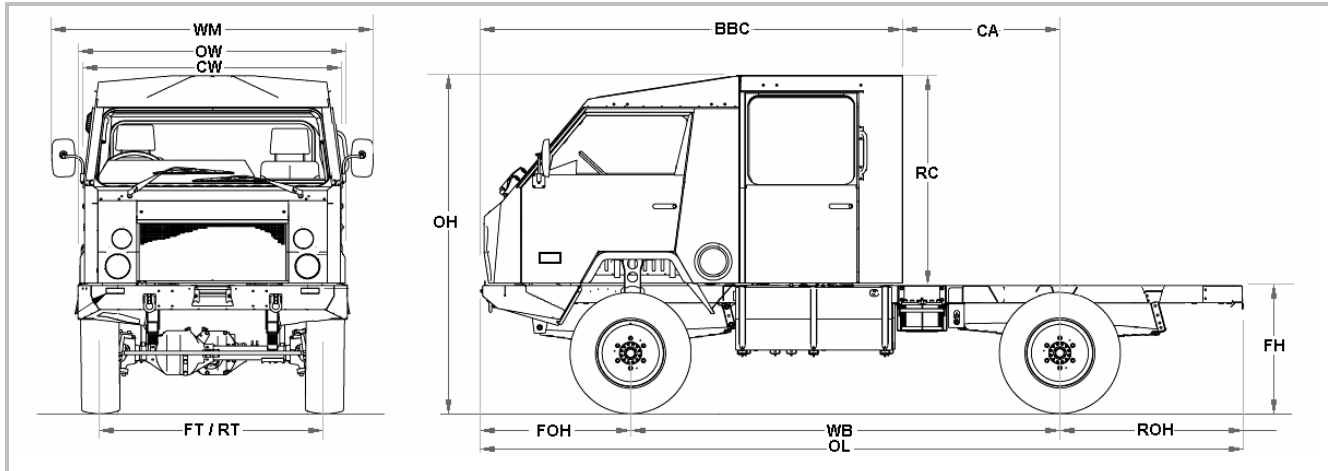

# OKA NT 4x4 Dual Cab Chassis

## EURO 5 NT24 E5 65-185 (with 4 seats in module)

### Technical data MY2011



**Dimensions mm** (Fully fuelled, unladen. Drawing may depict optional equipment)

OL Overall Length	OH Overall Height	OW Overall Width	CW Cab Width	WM Width Mirrors	FT Front Track	RT Rear Track
5648	2508	2000	1900	2340	1664	1664
WB Wheelbase	FOH Front O'hang	ROH Rear O'hang	BBC Cab Length	CA Cab to R Axle	FH Frame Height	RC Rear of Cab
3190	1101	1357	3124	1167	950	1558

#### Engine

- Emission class EURO5
- Type Cummins ISB4.5E5185
- No. and arrangement of cylinders 4 in-line
- Technology SCR
- Diesel direct injection turbocharged & intercooled 4 stroke
- Power output kW (hp) 136 (185)
- At rated speed rev/min 2500
- Maximum torque Nm 700
- At rated speed rev/min 1200-1700
- Displacement cm<sup>3</sup> 4500
- Coolant – water With thermostat Thermostatic fan
- Fuel tank litres 120
- AdBlue tank litres 43

#### Transmission

- Allison 1000 series automatic with park pawl  
6 forward gears, 1 reverse
- Ratio spread 3.10-0.61:1
  - Torque converter stall 1.73:1
- With power and economy modes  
With overdrive (5<sup>th</sup> & 6<sup>th</sup> gear) lock-out
- Transfer box OKA HD250
- Ratio High 1.00:1
  - Low 2.00:1
- Available combinations 4 High
  - 4 Low
  - Neutral
  - 2 High

#### Axles

- Front axle: OKA heavy duty beam type - drive steer with free-wheeling hubs and hub step
- Ratio 4.62:1
  - Capacity kg 3200
- Rear axle: OKA heavy duty beam type
- Ratio 4.62:1
  - Capacity kg 3800

#### Brakes

- Service brake: Ventilated disc brakes front and rear. Power boosted air over hydraulic
- Diameter front mm 350
  - Diameter rear mm 350
- Park brake: Drum type on transfer case – spring application, air release
- Drum diameter mm 178

#### Steering

Power assisted variable ratio with damper

#### Suspension

- Front: 12 leaf OKA Flex suspension with single rate semi-elliptic multi-leaf springs and Aeon second stage helper springs. High performance long-stroke double acting shock absorbers
- Rear: 13 leaf OKA Flex suspension with dual rate semi-elliptic multi-leaf springs and Aeon third stage helper springs. High performance long-stroke double acting shock absorbers.

#### Wheels and tyres

- Wheels: 4 road wheels (single on rear)  
Rim size: 19.5" x 8.25" one piece rim  
Tyres: 305/70R19.5 Continental HDR  
Spare wheel and tyre on winch type carrier

#### Chassis

- Box section straight rail  
Flat welded ladder frame construction

#### Electrics

- System: 24 V, 90 Amp alternator.  
Lighting: Dual beam headlamps and driving lights, Indicators.

#### Cab (standard equipment)

- Forward control 4 door welded construction, with zinc coated steel sheet panels, built to ROPS safety standard (AS1636-1984)  
Laminated windscreen, 2 speed + intermittent wipers and washers. Rear view mirrors.  
2 seats with seatbelts (single action, detachable for easy servicing), with 4 fixed seats in module.  
Steering lock, demister, interior sunvisors, glove box, cigarette lighter. Driver's cab air-conditioning. Radio AM/FM/CD  
Sliding side windows in module  
Gauges: Speedometer, trip meter, odometer, tachometer, fuel level, water temperature, oil pressure, volt meter, clock  
Warning lights: Oil pressure, water temp, charge high beam, indicators, brake failure, 4WD Engagement.

#### Weights (basic execution)

- |                             |    |      |
|-----------------------------|----|------|
| Gross vehicle mass GVM      | kg | 6500 |
| Permissible front axle load | kg | 3200 |
| Permissible rear axle load  | kg | 3800 |
| Tare weight*                | kg | 4235 |
| Gross Payload*              | kg | 2265 |
| GCM                         | kg | 9000 |
| Max braked trailer weight   | kg | 4500 |
- \*Tare and payload do not take into account weight of tray bodies or options

### Performance indicator

• Maximum cruising	Km/h	120
• Maximum gradient	%	55
• Turning circle	m	14.5

### Optional accessories

- Dropside steel tray 2395 mm (2 pallet) internal length (add 305kg)
- Alternative tray 1770mm (add 247kg)
- Tail lamp kit
- Rear light bar
- Front axle differential lock
- Rear axle differential lock
- Air-conditioning ducted to rear of cab for body - various possibilities of ducting / fans
- Bull bar
- Tow bar
- Cruise control (manual or auto)
- Hub step – rear wheels
- External sun visor
- Fire Extinguisher
- Auxiliary fuel tank 170 litres
- Water tank 95 litres
- Auxiliary battery system
- Electric winch – capacity 15000 lb (66.7kN)
- Bluetooth radio AM/FM/CD
- Bluetooth radio AM/FM/CD with PA system
- Speed limiter setting
- Tropical roof + rack
- Auto air step
- Fixed side windows in module
- Rust proofing
- Light bar with beacons and work light
- First aid kit
- Tachograph
- Spotlights
- Pacbrake PRXB exhaust brake
- Air access point

### Special Vehicle Options

- 335/80R20 Michelin XZL tyres On 9.00" x 20" 3 piece rims
- CTIS (central tyre inflation system) kit on 8.25" x 19.5" rims with beadlock
- CTIS (central tyre inflation system) kit on 9.00" x 20" rims with beadlock
- Air beadlock for 8.25" x 19.5" 1 piece rim
- Air beadlock for 9.00" x 20" 3 piece rim
- Air beadlock for 8.25" x 19.5" bolt-together
- Air beadlock for 9.00" x 20" bolt-together
- Rubber beadlock (for 20" split rims)
- Exit hatch on driver's cab
- NATO trailer hitch and trailer plugs

### Optional wheel and tyres

- Bolt-together rims 8.25" x 19.5"
- Hankook DH05 305/70R19.5 tyres
- Additional spare wheel and tyre assembly to match tyre equipment fitted

### Optional seating

- Vinyl seat trim
- Holdsworth seat trim
- Rear fixed seat vinyl
- Rear fixed seat Holdsworth
- Rear reclining seats vinyl
- Rear reclining seats wool moquette
- Rear reclining seats Holdsworth
- Rear mining seats vinyl

### Optional seating layouts

Standard – 4 seats in module

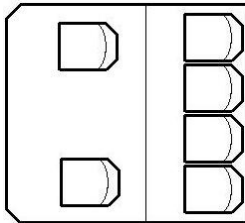

Optional – 3 seats in module

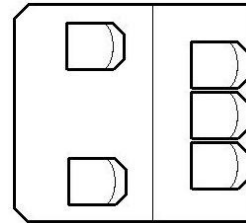

### OKA – all terrain solutions

Designed and manufactured in Australia by

### Reymer Pty. Ltd.

45 Miguel Road (PO Box 1307, Bibra Lake, WA 6965)

Bibra Lake, WA 6163

Tel; (+61) 08 9434 1300, Fax; (+61) 08 9434 1659,

e-mail; sales@oka.com.au, web; www.oka.com.au

ABN 91009250784