

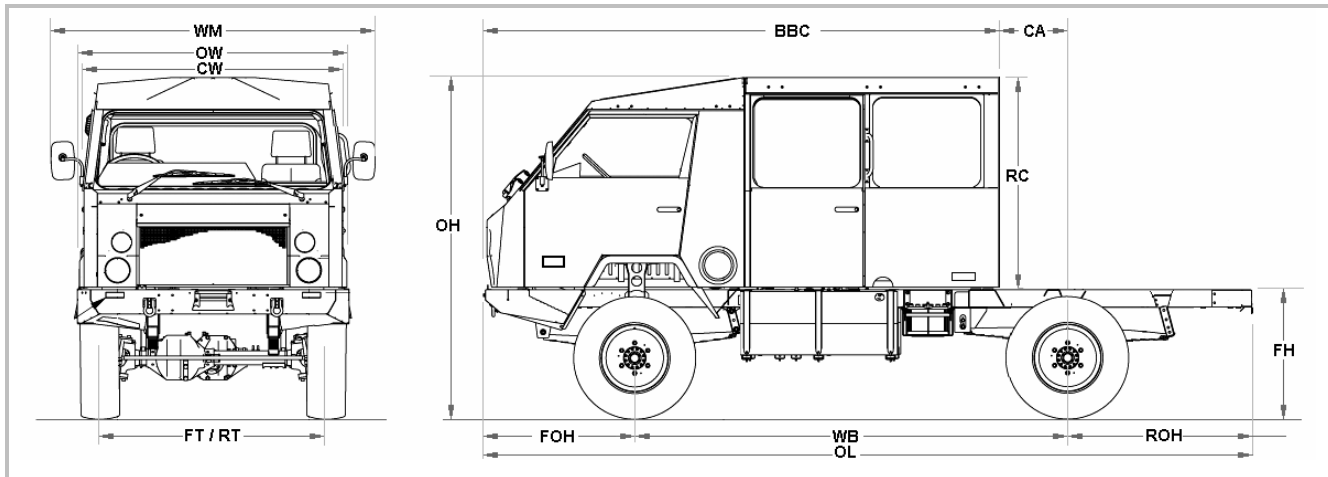

OKA NT 4x4 Multi Cab Chassis

EURO 5 NT24 E5 65-185 (with 7 seats in module)

Technical data MY2011



Dimensions mm (Fully fuelled, unladen. Drawing may depict optional equipment)

OL Overall Length	OH Overall Height	OW Overall Width	CW Cab Width	WM Width Mirrors	FT Front Track	RT Rear Track
5648	2508	2000	1900	2340	1664	1664
WB Wheelbase	FOH Front O'hang	ROH Rear O'hang	BBC Cab Length	CA Cab to R Axle	FH Frame Height	RC Rear of Cab
3190	1101	1357	3800	491	950	1558

Engine

- Emission class: EURO5
- Type: Cummins ISB4.5E5185
- No. and arrangement of cylinders: 4 in-line
- Technology: SCR
- Diesel direct injection turbocharged & intercooled: 4 stroke
- Power output: kW (hp) 136 (185)
- At rated speed: rev/min 2500
- Maximum torque: Nm 700
- At rated speed: rev/min 1200-1700
- Displacement: cm³ 4500
- Coolant – water: With thermostat Thermostatic fan
- Fuel tank: litres 120
- AdBlue tank: litres 43

Transmission

- Allison 1000 series automatic with park pawl
6 forward gears, 1 reverse
- Ratio spread: 3.10-0.61:1
 - Torque converter stall: 1.73:1
- With power and economy modes
With overdrive (5th & 6th gear) lock-out
- Transfer box: OKA HD250
- Ratio: High 1.00:1
Low 2.00:1
 - Available combinations: 4 High
4 Low
Neutral
2 High

Axles

- Front axle: OKA heavy duty beam type - drive steer with free-wheeling hubs and hub step
- Ratio: 4.62:1
 - Capacity: kg 3200
- Rear axle: OKA heavy duty beam type
- Ratio: 4.62:1
 - Capacity: kg 3800

Brakes

- Service brake: Ventilated disc brakes front and rear. Power boosted air over hydraulic
- Diameter front: mm 350
 - Diameter rear: mm 350
- Park brake: Drum type on transfer case – spring application, air release
- Drum diameter: mm 178

Steering

Power assisted variable ratio with damper

Suspension

- Front: 12 leaf OKA Flex suspension with single rate semi-elliptic multi-leaf springs and Aeon second stage helper springs. High performance long-stroke double acting shock absorbers
- Rear: 13 leaf OKA Flex suspension with dual rate semi-elliptic multi-leaf springs and Aeon third stage helper springs. High performance long-stroke double acting shock absorbers.

Wheels and tyres

- Wheels: 4 road wheels (single on rear)
Rim size: 19.5" x 8.25" one piece rim
Tyres: 305/70R19.5 Continental HDR
Spare wheel and tyre on winch type carrier

Chassis

- Box section straight rail
Flat welded ladder frame construction

Electrics

- System: 24 V, 90 Amp alternator.
Lighting: Dual beam headlamps and driving lights, Indicators.

Cab

- Forward control 3 door welded construction, with zinc coated steel sheet panels, built to ROPS safety standard (AS1636-1984)
Laminated windscreen, 2 speed + intermittent wipers and washers. Rear view mirrors.
2 seats with seatbelts (single action, detachable for easy servicing), plus 2/3 fixed seats in second row and 3/4 fixed seats in third row.
Steering lock, demister, interior sunvisors, glove box, cigarette lighter. Driver's cab air-conditioning.
Radio AM/FM/CD. Sliding side windows in module.
Gauges: Speedometer, trip meter, odometer, tachometer, fuel level, water temperature, oil pressure, volt meter, clock
Warning lights: Oil pressure, water temp, charge high beam, indicators, brake failure, 4WD Engagement.

Weights (basic execution)

- | | | |
|-----------------------------|----|------|
| Gross vehicle mass GVM | kg | 6500 |
| Permissible front axle load | kg | 3200 |
| Permissible rear axle load | kg | 3800 |
| Tare weight* | kg | 4467 |
| Gross Payload* | kg | 2033 |
| GCM | kg | 9000 |
| Max braked trailer weight | kg | 4500 |
- *Tare and payload do not take into account weight of tray bodies or options

Performance indicator

- Maximum cruising Km/h 120
- Maximum gradient % 55
- Turning circle m 14.5

Optional accessories

- Dropside steel tray 1770 mm internal length*
- Tail lamp kit
- Rear light bar
- Front axle differential lock
- Rear axle differential lock
- Air-conditioning ducted to rear of cab for body - various possibilities of ducting / fans
- Bull bar
- Tow bar
- Cruise control (manual or auto)
- Hub step – rear wheels
- External sunvisor
- Fire Extinguisher
- Auxiliary fuel tank 170 litres
- Water tank 95 litres
- Auxiliary battery system
- Electric winch – capacity 15000 lb (66.7kN)
- Bluetooth radio AM/FM/CD
- Bluetooth radio AM/FM/CD with PA system
- Speed limiter setting
- Tropical roof + rack
- Auto air step
- Fixed side windows in module
- Rust proofing
- Light bar with beacons and worklight
- First aid kit
- Tachograph
- Hour meter
- Spotlights
- Pacbrake PRXB exhaust brake
- Air access point

* add 247 kg

Special Vehicle Options

- 335/80R20 Michelin XZL tyres
On 9.00" x 20" 3 piece rims
- CTIS (central tyre inflation system) kit on 8.25" x 19.5" rims with beadlock
- CTIS (central tyre inflation system) kit on 9.00" x 20" rims with beadlock
- Air beadlock for 8.25" x 19.5" 1 piece rim
- Air beadlock for 9.00" x 20" 3 piece rim
- Air beadlock for 8.25" x 19.5" bolt-together
- Air beadlock for 9.00" x 20" bolt-together
- Rubber beadlock (for 20" split rims)
- Exit hatch on driver's cab
- NATO black-out lighting
- NATO trailer hitch and trailer plugs

Optional wheel and tyres

- Bolt-together rims 8.25" x 19.5"
- Hankook DH05 305/70R19.5 tyres
- Additional spare wheel and tyre assembly to match tyre equipment fitted

Optional seating

- Vinyl seat trim
- Holdsworth seat trim
- Rear fixed seat vinyl
- Rear fixed seat wool moquette
- Rear fixed seat Holdsworth
- Rear reclining seats vinyl
- Rear reclining seats wool moquette
- Rear reclining seats Holdsworth
- Rear mining seats vinyl
- Module seat footrests*
- Module seat map pockets*
*except mining seats

Optional seating layouts

Standard - 7 seats in module

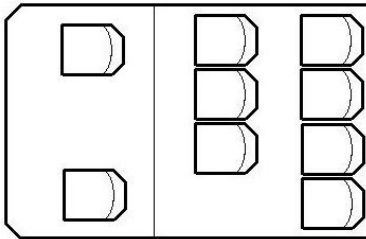

Optional - 6 seats (3+3) in module

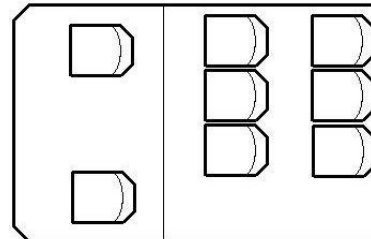

Optional - 6 seats (2+4) in module

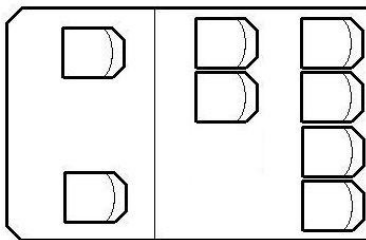

OKA – all terrain solutions

Designed and manufactured in Australia by

Reymer Pty. Ltd.

45 Miguel Road (PO Box 1307, Bibra Lake, WA 6965)

Bibra Lake, WA 6163

Tel; (+61) 08 9434 1300, Fax; (+61) 08 9434 1659,

e-mail; sales@oka.com.au, web; www.oka.com.au

ABN 91009250784

Dealer