

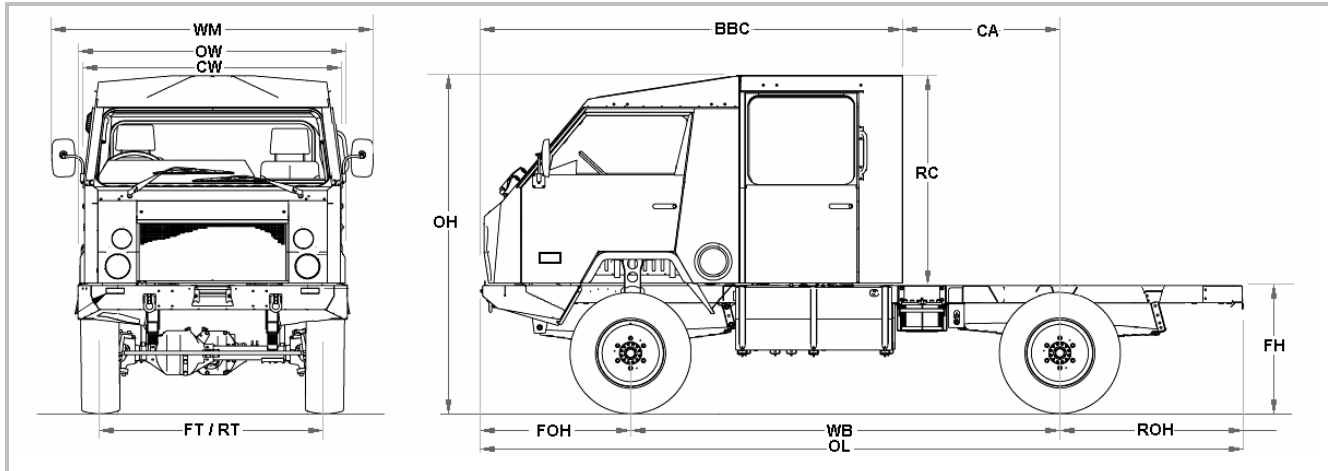

# OKA NT 4x4 Dual Cab Chassis

## EURO 3 NT24 E3 65-185 (with 4 seats in module)

### Technical data



**Dimensions mm** (Fully fuelled, unladen. Drawing may depict optional equipment)

OL Overall Length	OH Overall Height	OW Overall Width	CW Cab Width	WM Width Mirrors	FT Front Track	RT Rear Track
5648	2508	2000	1900	2340	1664	1664
WB Wheelbase	FOH Front O'hang	ROH Rear O'hang	BBC Cab Length	CA Cab to R Axle	FH Frame Height	RC Rear of Cab
3190	1101	1357	3124	1167	950	1558

#### Engine

- Emission class EURO3
- Type Cummins ISB4.5E3185
- No. and arrangement of cylinders 4 in-line
- Technology Electronic 4 stroke
- Diesel direct injection turbocharged & intercooled
- Power output kW (hp) 136 (185)
- At rated speed rev/min 2500
- Maximum torque Nm 650
- At rated speed rev/min 1200-1700
- Displacement cm<sup>3</sup> 4500
- Coolant – water With thermostat Thermostatic fan
- Fuel tank litres 170

#### Axes

- Front axle: OKA heavy duty beam type - drive steer with hub step
- Ratio 4.62:1
  - Capacity kg 3200
- Rear axle: OKA heavy duty beam type
- Ratio 4.62:1
  - Capacity kg 3800

#### Chassis

- Box section straight rail
- Flat welded ladder frame construction

#### Electrics

- System: 24 V, 90 Amp alternator.
- Lighting: Dual beam headlamps and driving lights, Indicators.

#### Brakes

- Service brake: Ventilated disc brakes front and rear. Power boosted air over hydraulic
- Diameter front mm 350
  - Diameter rear mm 350
- Park brake: Drum type on transfer case – spring application, air release
- Drum diameter mm 178

#### Cab (standard equipment)

- Forward control 4 door welded construction, with zinc coated steel sheet panels, built to ROPS safety standard (AS1636-1984)
- Laminated windscreen, 2 speed + intermittent wipers and washers. Rear view mirrors.
- 2 seats with seatbelts (single action, detachable for easy servicing), with 4 fixed seats in module.
- Steering lock, demister, interior sunvisors, glove box, cigarette lighter. Driver's cab air-conditioning. Radio AM/FM/CD
- Sliding side windows in module

#### Steering

- Power assisted variable ratio with damper

#### Suspension

- Front: 12 leaf OKA Flex suspension with single rate semi-elliptic multi-leaf springs and Aeon second stage helper springs. High performance long-stroke double acting shock absorbers
- Rear: 13 leaf OKA Flex suspension with dual rate semi-elliptic multi-leaf springs and Aeon third stage helper springs. High performance long-stroke double acting shock absorbers.

#### Wheels and tyres

- Wheels: 4 road wheels (single on rear)
- Rim size: 19.5" x 8.25" one piece rim
- Tyres: 305/70R19.5 Continental HDR
- Spare wheel and tyre

#### Transmission

- Clutch: 330mm single plate hydraulic

- Gearbox: Tremec TR4050 manual all synchromesh, 5 gears forward, 1 reverse

- Ratio spread 5.81-0.77:1

#### Optional Gearbox:

- Allison 1000 series automatic with park pawl 6 forward gears, 1 reverse

- Ratio spread 3.10-0.61:1
- Torque converter stall 1.73:1

#### Transfer box

- Ratio High 1.00:1
- Low 2.00:1

- Available combinations 4 High

- 4 Low
- Neutral
- 2 High

#### OKA HD250

#### Weights (basic execution)

Gross vehicle mass GVM	kg	6500
Permissible front axle load	kg	3200
Permissible rear axle load	kg	3800
Tare weight*	kg	4235
Gross Payload*	kg	2265
GCM	kg	9000
Max braked trailer weight	kg	4500

\*Tare and payload do not take into account weight of tray bodies or options

### Performance indicator

• Maximum cruising	Km/h	120
• Maximum gradient	%	55
• Turning circle	m	14.5

### Optional wheel and tyres

- Fitted 305/70R19.5 Continental HDR tyres on bolt-together rims 8.25" x 19.5"
- Spare one price rim size 8.25" x 19.5"
- Spare bolt-together rim 8.25" x 19.5"
- Spare tyre 305/70R19.5
- Hankook DH05 305/70R19.5 tyres
- Additional spare wheel and tyre assembly to match tyre equipment fitted
- Winch type spare wheel carrier

### Optional accessories

- Dropside steel tray 2395 mm (2 pallet) internal length (add 305kg)
- Alternative tray 1770mm (add 247kg)
- Tail lamp kit
- Rear light bar
- Front axle differential lock
- Rear axle differential lock
- Air-conditioning ducted to rear of cab for body - various possibilities of ducting / fans
- Bull bar
- Tow bar
- Free wheeling hubs
- Cruise control (manual or auto)
- Hub step – rear wheels
- External sunvisor
- Fire Extinguisher
- Auxiliary fuel tank 170 litres
- Water tank 95 litres
- Auxiliary battery system
- Electric winch – capacity 15000 lb (66.7kN)
- Radio AM/FM/CD with PA system
- Speed limiter setting
- Tropical roof + rack
- Auto air step
- Fixed side windows in module
- Rust proofing
- Light bar with beacons and worklight
- First aid kit
- Tachograph
- Hour meter
- Spotlights
- Pacbrake PRXB exhaust brake

### Special Vehicle Options

- 335/80R20 Michelin XZL tyres
- CTIS (central tyre inflation system) kit on 8.25" x 19.5" rims with beadlock
- CTIS (central tyre inflation system) kit on 9.00" x 20" rims with beadlock
- Air beadlock for 8.25" x 19.5" 1 piece rim
- Air beadlock for 9.00" x 20" 3 piece rim
- Air beadlock for 8.25" x 19.5" bolt-together
- Air beadlock for 9.00" x 20" bolt-together
- Rubber beadlock (for 20" split rims)
- Exit hatch on driver's cab
- NATO black-out lighting
- NATO trailer hitch and trailer plugs

### Optional seating

- Vinyl seat trim
- Holdsworth seat trim
- Rear fixed seat vinyl
- Rear fixed seat Holdsworth
- Rear reclining seats vinyl
- Rear reclining seats wool moquette
- Rear reclining seats Holdsworth
- Rear mining seats vinyl

### Optional seating layouts

Standard – 4 seats in module

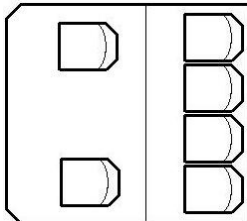

Optional – 3 seats in module

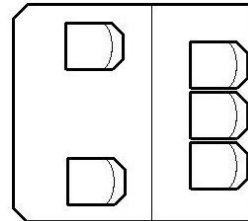

### OKA – all terrain solutions

Designed and manufactured in Australia by

### Reymer Pty. Ltd.

45 Miguel Road (PO Box 1307, Bibra Lake, WA 6965)

Bibra Lake, WA 6163

Tel; (+61) 08 9434 1300, Fax; (+61) 08 9434 1659,

e-mail; sales@oka.com.au, web; www.oka.com.au

ABN 91009250784